

UC-NRLF

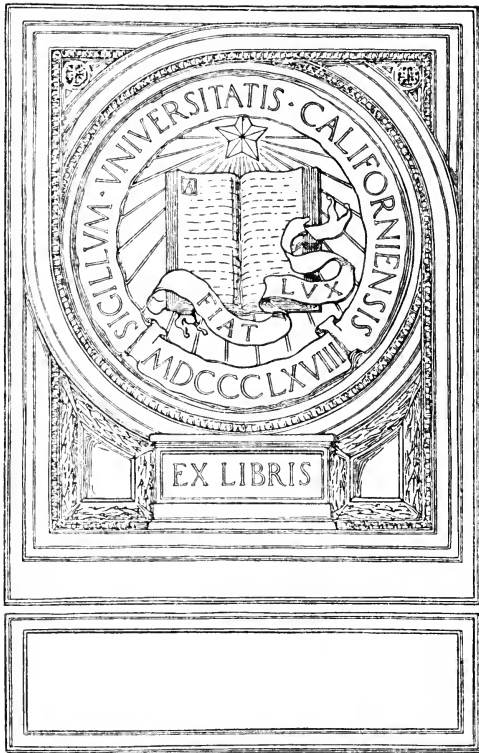

QB 26 205

YC 12973





INFLUENCE DIAGRAMS

FOR THE

DETERMINATION OF MAXIMUM MOMENTS IN TRUSSES AND BEAMS

BY

MALVERD A. HOWE, C.E.

PROFESSOR OF CIVIL ENGINEERING, ROSE POLYTECHNIC INSTITUTE
MEMBER AMERICAN SOCIETY OF CIVIL ENGINEERS

FIRST EDITION

FIRST THOUSAND

NEW YORK

JOHN WILEY & SONS, INC.

LONDON: CHAPMAN & HALL, LIMITED

1914

75

Copyright, 1914
BY
MALVERD A. HOWE

TO THE
AMERICAN

THE SCIENTIFIC PRESS
ROBERT DRUMMOND AND COMPANY
BROOKLYN, N. Y.

PREFACE

THE use of influence lines for the determination of maximum moments and criterions for wheel loads is presented in many modern text books.

The object of these few pages is to bring attention to the fact that for loads on all ordinary trusses, the influence diagrams for bending moments are drawn by following a single simple rule, and that the diagrams so constructed require no computations for their direct application. In addition to this the influence diagrams for loads on continuous trusses, cantilever trusses and arches are shown to be based upon the one general diagram for simple trusses.

While the diagrams, as a rule, are constructed for moments yet they can be as easily drawn for stresses or even areas of truss members.

The use of the influence diagrams in the determination of criterions for the positions of wheel loads which produce maximums is explained and shown to be very simple.

M. A. H.

DECEMBER, 1913.

TABLE OF CONTENTS

CHAPTER I

SIMPLE TRUSSES

	PAGE
Rule for Drawing Influence Diagrams.....	2
Diagonal of Pratt Truss.....	3
Load Position for Maximum Moment.....	5
Neutral Point.....	7
Vertical of Pratt Truss.....	8
Web Member of Warren Truss.....	9
Web Members in Simple Trusses having Parallel Chords.....	9
Bottom Chord of Curved Chord Simple Truss.....	12
Top Chord of Curved Chord Simple Truss.....	13
Bottom Chord of Curved Chord Warren Truss.....	14
Trusses with Sub-divided Panels.....	15
Lower Segment of Diagonal in Sub-strut Truss.....	15
Upper Segment of Diagonal in Sub-strut Truss.....	17
Vertical of Sub-strut Truss.....	18
Upper Segment of Diagonal in Sub-hanger Truss.....	19
Lower Segment of Diagonal in Sub-hanger Truss.....	20
Vertical of Sub-hanger Truss.....	21
Bottom Chord of Sub-strut Truss.....	21
Top Chord of Sub-strut Truss.....	23
Top Chord of Sub-hanger Truss.....	24
Bottom Chord of Sub-hanger Truss.....	25
The Length of the Cut Stringer.....	26
Diagonal of Simple Truss having Center of Moments between the Supports.....	27
Vertical of Simple Truss having Center of Moments between the Supports.....	28

CHAPTER II

DOUBLE INTERSECTION TRUSSES

	PAGE
Double Intersection Trusses.....	30
Top Chord of Whipple Truss.....	30
Vertical of Whipple Truss.....	31
Diagonal of Whipple Truss.....	32
Top Chord of Sub-divided Double Triangular Truss.....	32
Bottom Chord of Sub-divided Double Triangular Truss.....	33
Lower Segment of Diagonal in Sub-divided Double Triangular Truss...	35
Chords of the <i>K</i> Truss.....	35
Diagonal Web Members of the <i>K</i> Truss.....	36
Upper Segment of Vertical in the <i>K</i> Truss.....	38
Lower Segment of Vertical in the <i>K</i> Truss.....	39

CHAPTER III

CONTINUOUS TRUSSES

The Moment Influence Diagrams.....	41
General Moment Formula.....	41
Cantilever Truss.....	43
Top Chord of Anchor Span.....	43
Top Chord of Cantilever Span.....	44
Diagonal of Anchor Span.....	46
Diagonal of Cantilever Span.....	47
Partially Continuous Truss.....	48
Top Chord of a Partially Continuous Truss.....	49
Diagonal of a Partially Continuous Truss.....	52
Continuous Truss of Two Equal Spans.....	53

CHAPTER IV

ARCHES

Arches.....	55
Diagonals of a Three-hinged Arch with Open Web.....	55
Chord of a Two-hinged Arch with Open Web.....	57
Diagonal of a Two-hinged Arch with Open Web.....	58

TABLE OF CONTENTS

vii

	PAGE
Moment Influence Diagram for Two-hinged Arch with Solid Web.....	59
Vertical Shear for Two-hinged Arch with Solid Web.....	59

CHAPTER V

BEAMS OF CONSTANT CROSS-SECTION

The Influence Diagram.....	60
Restrained Beams.....	60
Simple Beam on Two Supports.....	61
Beam Fixed at One End and Supported at the Other End.....	62
Beam Fixed at Both Ends.....	63

DEFINITION

An influence diagram is one which shows the effect of a unit load moving across a structure upon any function of the structure for any position of the load.



INFLUENCE DIAGRAMS FOR THE DETERMINATION
OF MAXIMUM MOMENTS

CHAPTER I

SIMPLE TRUSSES*

An Influence Line for the bending moments at the center of moments for any member of a truss on two supports for vertical loads can be constructed by a method which is perfectly general in its application. The truss may be of any shape, and the loads may be applied to either the upper- or lower-chord joints.

A section is passed through the truss, in the usual manner, cutting the member whose influence line is to be drawn. This section must evidently also cut a stringer in the panel of the truss containing the cut loaded chord. Let:

d = the horizontal projection of the length of the stringer which is cut by the section. This stringer will be called the *cut stringer*.

b = the horizontal distance from the left support of the truss to the left end of the *cut stringer*.

* See "General Method for Drawing Influence Lines for Stress in Simple Trusses," by Malverd A. Howe. *Engineering News*, June 12, 1913.

s = the horizontal distance from the left support of the truss to the center of moments. s will be considered positive when measured to the right.

h = the vertical distance, at the *left* end of the *cut stringer*, between the two chord members which are cut by the section.

h' = the vertical distance between the same chords at the *right* end of the *cut stringer*.

The General Rule for drawing the influence line is as follows:

(a) Through any point A (refer to Fig. 1; the other figures are lettered correspondingly) in a vertical line passing through the center of moments, draw a horizontal line cutting the vertical line through the left support of the truss at C and the vertical line through the right support at D .

(b) From C , at *any convenient scale*, lay off vertically downward the distance $CD = AC = s$, and connect B and D by a straight line.

(c) Through A and D draw a straight line and prolong it until it cuts the vertical line drawn through the *left* end of the *cut stringer* at E .

(d) Draw a vertical line through the *right* end of the *cut stringer*, intersecting the line ACB at F , and connect E and F by a right line.

(e) The polygon $DEFBD$ contains the influence line sought; the ordinates between the line $DEFB$ and the line DB are the respective moments for unit loads on the truss vertically above them, i.e., the lines $ef = z_1$, $rc = z_2$, $gk = z_3$, are proportional to the stresses produced by loads of one pound at W_1 , W_2 and W_3 , respectively. The ordinates are measured at the scale used in laying off the distance $CD = s$.

The application of the above rule to several forms of trusses will now be considered.

Diagonal of Pratt Truss with Inclined Top Chord.— Fig. 1 shows this truss and the influence diagram for the member UL' . The shaded area is the influence diagram.

To prove the construction correct, let the angles made with AB by the lines AE , EF and DB be respectively θ_1 , θ_2 and θ_3 , and let the distance from the left support of the truss to the unit load be, in general, represented by

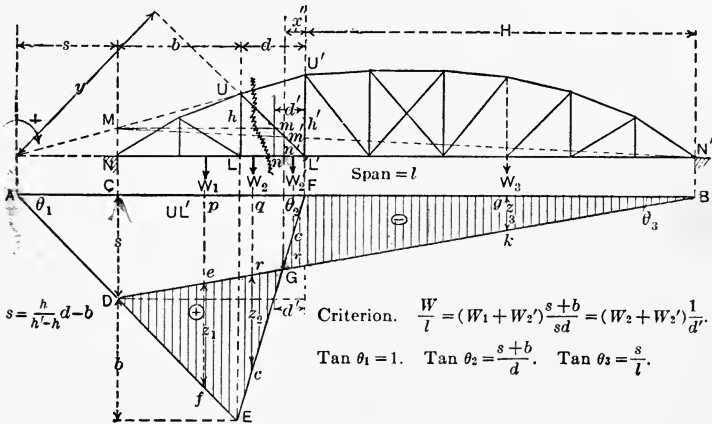

FIG. 1.

a. While the load W_1 is to the left of the *cut stringer*, or to the left of the vertical through E , the moment is:

$$M_s = -W_1 \frac{l-a_1}{l} s + W_1 (s+a_1) = -W_1 (l-a_1) \frac{s}{l} + W_1 (s+a_1) \frac{1}{l}, \quad (1)$$

or

$$M_s = -W_1 (l-a_1) \tan \theta_3 + W_1 (s+a_1) \tan \theta_1, \quad (2)$$

$$= W_1 (-pe + fp) = W_1 (+ef). \quad (3)$$

Since the resultant moment is positive, the moment $UL'(y)$ is negative and therefore UL' is in compression.

If the load, W_2 (or W_2') is on the *cut stringer*, or between the verticals through E and F , the moment is, for W_2 ,

$$M_s = -W_2 \frac{l-a_2}{l} s + W_2 \frac{b+d-a_2}{d} (s+b) \quad . \quad . \quad (4)$$

$$= -W_2(l-a_2) \frac{s}{l} + W_2(b+d-a_2) \frac{s+b}{d}, \quad . \quad . \quad (5)$$

or

$$M_s = -W_2(l-a_2) \tan \theta_3 + W_2(b+d-a_2) \tan \theta_2; \quad (6)$$

and hence

$$M_s = W_2(-qr + qc) = W_2(+rc) \quad . \quad . \quad . \quad (7)$$

Since the resultant moment is positive the stress in UL' is compressive.

For the load W_2'

$$M_s = W_2'(-rc), \quad . \quad . \quad . \quad . \quad (8)$$

and UL' is in tension.

When the load is between the *cut stringer* and the right support of the truss, the moment is:

$$M_s = -W_3 \frac{l-a_3}{l} s = -W_3(l-a_3) \frac{s}{l} = -W_3(l-a_3) \tan \theta_3,$$

or

$$M_s = W_3(-gk), \quad . \quad . \quad . \quad . \quad (9)$$

and the member UL' is in tension.

If the diagonal inclines in the opposite direction, as in a Howe truss, the construction of the influence diagram remains unchanged but the character of the stress is reversed.

Load-position for Maximum Moment. — For uniform loads, the influence diagram $DEGFB$ at once indicates the portions of the span which are loaded to produce like moments and hence maximum stresses.

The criterion for giving the position of wheel loads producing the maximum moment is readily found from the influence diagram. For cases which usually occur in practice, the portion of the span on the left of the *cut stringer* may be considered as unloaded. For convenience W_2 is assumed to represent all of the loads between the verticals through E and G concentrated at their center of gravity, W_2' all of the loads between the verticals through G and F , and W_3 all of the loads between the verticals through F and B . Let z_2 , z_2' and z_3 , be the ordinates of the influence diagram directly below the wheel loads W_2 , W_2' and W_3 . The moment is

$$M_s = W_2(z_2) - W_2'(z_2') - W_3(z_3). \quad (10)$$

If the loads move toward the left a distance δx , and no additional load comes on the span from the right and no load moves off the left end of the *cut stringer*, the moment becomes:

$$M_s' = W_2(z_2 - \delta x \tan \theta_3 + \delta x \tan \theta_2) - W_2'(z_2' + \delta x \tan \theta_3 - \delta x \tan \theta_2) - W_3(z_3 + \delta x \tan \theta_3). \quad (11)$$

The difference between these moments is,

$$M_s' - M_s = \delta M_s = W_2(-\tan \theta_3 + \tan \theta_2) \delta x - W_2'(\tan \theta_3 - \tan \theta_2) \delta x - W_3(\tan \theta_3) \delta x. \quad (12)$$

Dividing through by δx and placing $\frac{\delta M_s}{\delta x} = 0$,

$$\frac{\delta M_s}{\delta x} = (W_2 + W_2' + W_3)(-\tan \theta_3) + (W_2 + W_2')(\tan \theta_2) = 0 \quad (13)$$

$$= -(W)\frac{s}{l} + (W_2 + W_2')\frac{s+b}{d} = 0, \quad (14)$$

where $W = W_2 + W_2' + W_3 =$ the total load on the span.

Therefore, from equation (14), the desired criterion is

$$\frac{W}{l} = (W_2 + W_2')\frac{s+b}{sd} = \frac{W_2 + W_2'}{d'}, \quad . . . (15)$$

where

$$\frac{1}{d'} = \frac{s+b}{sd}, \quad \text{or} \quad d' = \frac{d}{s+b} s = \frac{s}{\tan \theta_2}. \quad . . . (16)$$

The value of d' is found graphically from the influence diagram by drawing a line through D parallel to CB until it cuts the vertical line through F , then d' is the distance indicated in the figure (Fig. 1 and those which follow). This value may also be found graphically without drawing the influence diagram by simply drawing in the truss diagram the line Mm parallel to the *bottom cut chord* LL' and prolonging it until it cuts a diagonal line drawn from the intersection of the cut top chord and a vertical through the left end of the *cut stringer* to the intersection of the cut bottom chord and the vertical through the right end of the *cut stringer*. This point is indicated by the letter m in the figure. The horizontal distance of this point m from

the vertical through the right end of the *cut stringer* is the value of d' . This is easily shown as follows: Fig. 1.

$$mn : h :: d' : d, \quad \text{or} \quad d' = \frac{d}{h}mn = \frac{d}{h}MN; \quad \dots \quad (17)$$

but

$$MN : s :: h : s+b, \quad \text{or} \quad MN = \frac{s}{s+b}h; \quad \dots \quad (18)$$

therefore

$$d' = \frac{s}{s+b}d = \frac{d}{s+b}s, \quad \dots \quad (19)$$

which is the value given in (16).

Neutral Point.—The position of a load which produces no stress in the web member UL' is indicated by the point G in the influence diagram, Fig. 1, since a load in the truss immediately above G produces no stress in the member as shown by a zero ordinate in the influence diagram. The point m' shown in the truss diagram is directly above G . This point is located by the intersection of the line MN' and the diagonal drawn as explained in determining d' . Let x' be the horizontal distance from m' to the vertical through the right end of the *cut stringer*, and $H+x'$ the horizontal distance of m' from the vertical through the right support of the truss. Then in Fig. 1

$$m'n' : h :: x' : d, \quad \text{or} \quad m'n' = \frac{h}{d}x' = MN(H+x')\frac{1}{l}; \quad (20)$$

but

$$MN : s :: h : s+b, \quad \text{or} \quad MN = \frac{s}{s+b}h; \quad \dots \quad (21)$$

hence

$$m'n' = \frac{H+x'}{l} \cdot \frac{s}{s+b} h = \frac{h}{d} x', \quad \dots \quad (22)$$

and

$$(H+x') \frac{s}{l} = \frac{s+b}{d} x'; \quad \dots \quad (23)$$

this becomes

$$(H+x') \tan \theta_3 = x' \tan \theta_2. \quad \dots \quad (24)$$

The ordinate above the point G in the influence diagram satisfies this equality, and therefore G and m' are in the same vertical line.

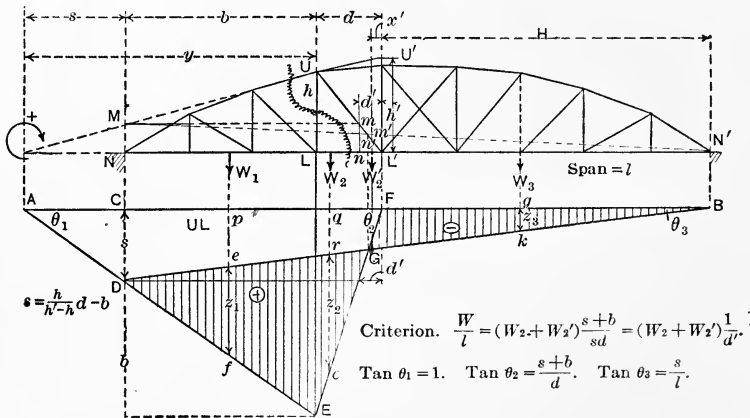

FIG. 2.

Vertical of Pratt Truss with Inclined Top Chord.—The truss diagram and the influence diagram are shown in Fig. 2.

All of the demonstrations given for Fig. 1 apply to Fig. 2. For all loads upon the left of the vertical through G the vertical is in tension and for those upon the right of G it is in compression.

Web Member of Warren Truss with Inclined Top Chord.
 —The web member $U'L$, Fig. 3 has been selected. A comparison with Fig. 1 shows that the influence diagram

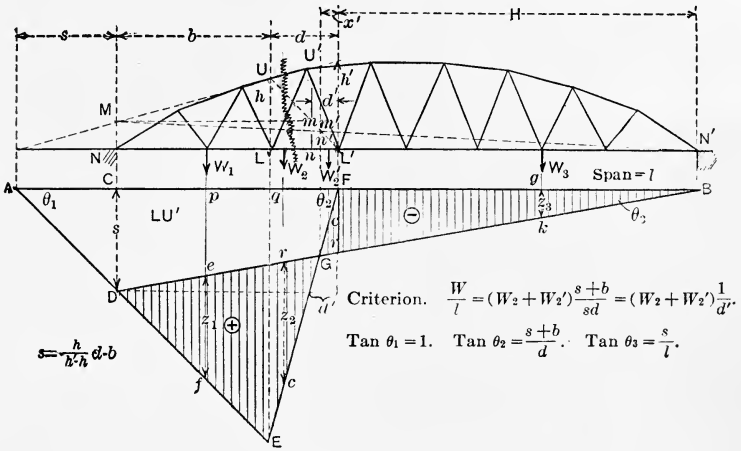

FIG. 3.

is constructed in exactly the manner followed in Fig. 1, and that all of the demonstrations of Fig. 1 apply equally well to Fig. 3. The locations of points m and m' are clearly shown in the figure where the verticals h and h' and the diagonal UL' are not members of the truss.

Web Members in Simple Trusses Having Parallel Chords.
 —The case shown in Fig. 4, presents an apparent exception to the general rule for drawing the influence line $DEFB$. The center of moments for any web member of a truss having parallel chords is at infinity. Taking N , the left

distance from N , will be sensibly parallel to ACB . It appears that the vertical shear influence diagram is constructed in precisely the manner outlined for the moment influence diagram when CD is made equal to unity.

For a load on the left of the vertical through E , the vertical shear between E and F is

$$-S = +W_1 \frac{l-a_1}{l} - W_1 = +W_1(l-a_1)\frac{1}{l} - W_1(1); \quad (27)$$

or

$$-S = +W_1(l-a_1) \tan \theta_5 - W_1(1) = W_1(+pe - pf);$$

therefore
$$+S = W_1(+ef). \quad . \quad . \quad . \quad (28)$$

In a similar manner it is shown that the ordinates directly below W_2 , W_2' and W_3 , represent the vertical shears produced by unit loads at these points.

A negative ordinate in the influence diagram indicates that the resultant shear acts upward; therefore the vertical component of the stress in the web member, for which the influence diagram is drawn, acts downward. In Fig. 4, the member $U'L'$ is in compression for loads on the left of G . The vertical UL has the same influence diagram but it is in tension for the same loads.

The criterion for maximum shear is determined in the manner given above for maximum moment. Without writing all of the equations and referring to equation (13) and Fig. 4,

$$\begin{aligned} \frac{\delta S}{\delta x} &= +W_2(-\tan \theta_5 + \tan \theta_4) - W_2'(-\tan \theta_4 + \tan \theta_5) \\ &\quad - W_3 \tan \theta_2 = 0. \quad . \quad . \quad . \quad . \quad . \quad (29) \end{aligned}$$

or

$$(W_2 + W_2' + W_3) \tan \theta_5 = (W_2 + W_2') \tan \theta_4, \quad (30)$$

which becomes

$$\frac{W_2 + W_2' + W_3}{l} = \frac{W_2 + W_2'}{d'} \dots \dots (31)$$

The points m and m' and the value of d' are found in the manner explained for Figs, 1, 2 and 3.

Bottom Chord of Curved-chord Simple Truss.—The influence diagram for this case is constructed according to the general directions as shown in Fig. 5. The points E and A coincide.

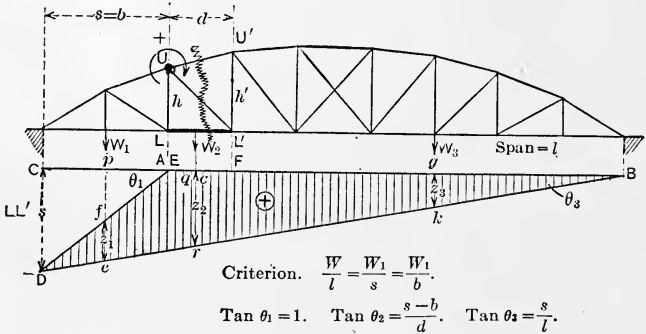

FIG. 5.

The positive sign indicates that the resultant moment is positive and that the moment of the stress in LL' is negative. This shows that LL' is in tension.

The criterion for the maximum moment when wheel loads are on the bridge is found as follows: (see equation 13).

$$\frac{\delta M_s}{\delta x} = W_1(-\tan \theta_1 + \tan \theta_3) + W_2 \tan \theta_3 + W_3 \tan \theta_3 = 0 \quad (32)$$

$$= (W_1 + W_2 + W_3) \tan \theta_3 - W_1 \tan \theta_1 = 0; \quad \dots \dots (33)$$

$$\frac{s}{l} = \frac{W_1}{b}$$

this becomes

$$\frac{W_1 + W_2 + W_3}{l} = \frac{W_1}{s} \dots \dots \dots (34)$$

An equivalent criterion is

$$\frac{W_2 + W_3}{l - s} = \frac{W_1}{s} = \frac{W_2 + W_3}{AB} = \frac{W_1}{AC} \dots \dots (35)$$

This criterion holds good for any influence diagram which is triangular in shape.

Top Chord of Curved-chord Simple Truss.—The construction of the influence diagram follows the same general rule

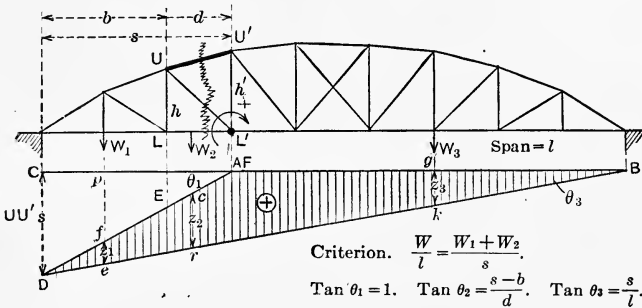

FIG. 6.

as in the previous case. The points A and F, Fig. 6 coincide, while E is on the right line connecting D and A since the line EF coincides with this line.

For wheel loads the criterion is

$$\frac{W_1 + W_2}{s} = \frac{W_3}{l - s} = \frac{W}{l}, \dots \dots \dots (36)$$

where W = the total load on the span.

Bottom Chord of Curved-chord Warren Truss.—If both sets of web members are inclined as shown in Fig. 7, the influence diagram remains unchanged in its construction, but the line EF does not coincide with the line DA as in the previous case.

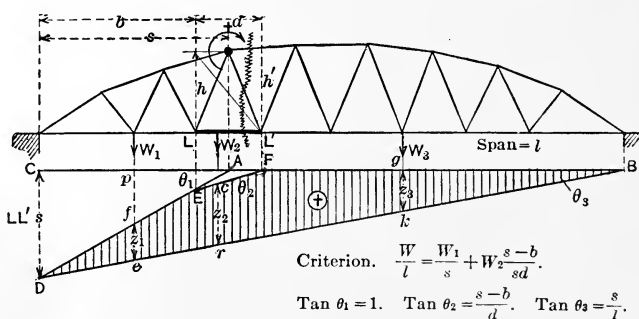

FIG. 7.

The criterion for the maximum moment produced by wheel loads is found as follows:

$$\frac{\delta M_s}{\delta x} = W_1(-\tan \theta_1 + \tan \theta_3) + W_2(-\tan \theta_2 + \tan \theta_3) + W_3 \tan \theta_3 = 0. \quad (37)$$

$$= (W_1 + W_2 + W_3) \tan \theta_3 - W_1 \tan \theta_1 - W_2 \tan \theta_2 = 0, \quad (38)$$

Substituting the values of the tangents, equation (38) becomes

$$(W_1 + W_2 + W_3) \frac{s}{l} - W_1 - W_2 \frac{s-b}{d} = 0. \quad (39)$$

Hence

$$\frac{W}{l} = \frac{W_1}{s} + W_2 \frac{s-b}{sd} \cdot \cdot \cdot \cdot \cdot \quad (40)$$

If $s - b = \frac{1}{2}d$, then

$$\frac{W}{l} = \frac{W_1 + \frac{1}{2}W_2}{s} \cdot \cdot \cdot \cdot \cdot \quad (41)$$

Trusses with Sub-divided Panels.—The usual type of truss with sub-divided panels has one set of web members vertical. The trusses here considered will have one set of web members vertical and the chords not parallel. The only difficulty in constructing the moment influence diagram is the determination of the proper length of the *cut stringer*. This once determined the construction of the diagram follows the general rule.

Lower Segment of Diagonal in Sub-strut Truss.—Let VL'' , Fig. 8, be the lower segment considered. This is a portion of the diagonal UL'' of the main truss and also forms a chord member of the auxiliary truss LVL'' .

Considering the member VL'' as a part of the diagonal of the main truss, the influence diagram $DD'FBD$ is constructed in the usual manner. The auxiliary truss LVL'' may be considered as a simple truss supported at L and L'' . The center of moments for VL'' may be taken anywhere in LL'' or LL'' produced and in order that the lever arm of VL'' shall be the same as that for UL'' the center of moments will be taken at the intersection of UU'' and LL'' produced, the center of moments for UL'' . The influence diagram, constructed according to the general rule, is $D'EB'$. Combining the two diagrams just constructed, the final influence diagram for VL'' is $DEFBD$. This diagram is the same as if constructed

with the horizontal projection of VL'' as the length of the *cut stringer*. The values of x' and d' can now be found in the usual manner from the truss diagram.

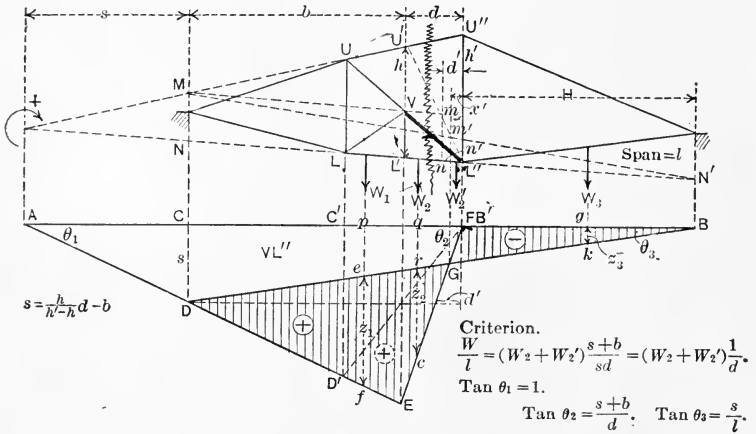

FIG. 8.

The criterion for the position of wheel loads producing maximum moment is found in the manner previously explained. Referring to equation (13) and Fig. 8.

$$\frac{\delta M_s}{\delta x} = W_2(-\tan \theta_3 + \tan \theta_2) - W_2'(\tan \theta_3 - \tan \theta_2) - W_3 \tan \theta_3 = 0, \quad (42)$$

or

$$(W_2 + W_2' + W_3) \tan \theta_3 = (W_2 + W_2') \tan \theta_2. \quad (43)$$

Substituting the values of the tangents

$$W \frac{s}{l} = (W_2 + W_2') \frac{s+b}{d}, \quad \dots \quad (44)$$

and

$$\frac{W}{l} = (W_2 + W_2') \frac{s+b}{sd} = \frac{(W_2 + W_2')}{d'} \quad \dots \quad (45)$$

which is the required criterion.

In case the chords are parallel s becomes ∞ and the criterion is

$$\frac{W}{l} = \frac{W_2 + W_2'}{d} \quad \dots \quad (46)$$

Upper Segment of Diagonal in Sub-strut Truss.—Referring to Fig. 9, it is clear that the diagonal UV has the

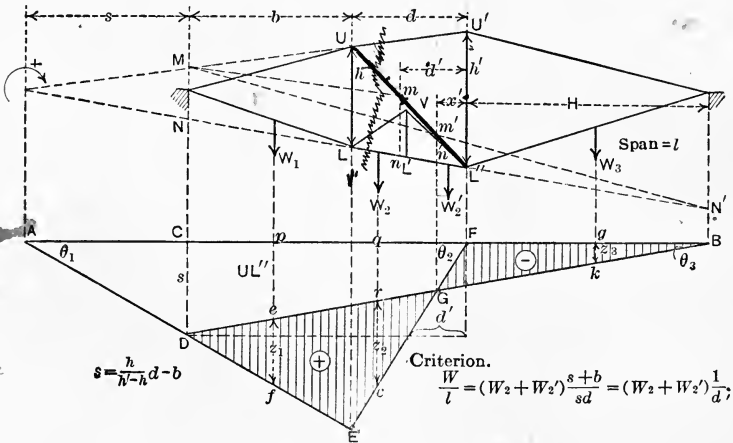

FIG. 9.

stress of UL' , the diagonal of the main truss, as the auxiliary truss LVL' simply serves the purpose of a *trussed stringer* extending from L to L' . The influence diagram is constructed according to the general rule taking the length of the *cut stringer* as the horizontal projection

of LL'' . The graphical determination of d' and x' is evident from the truss diagram.

The criterion for wheel loads producing maximum moment is

$$\left[\frac{W}{l} = (W_2 + W_2') \frac{s+b}{sd} \right] = (W_2 + W_2') \frac{1}{d'} \quad \dots (47)$$

If the chords are parallel the criterion becomes

$$\frac{W}{l} = \frac{W_2 + W_2'}{d} \quad \dots \dots \dots (48)$$

Vertical of Sub-strut Truss.—As indicated in Fig. 10, the vertical of a sub-strut truss is a member of the main truss.

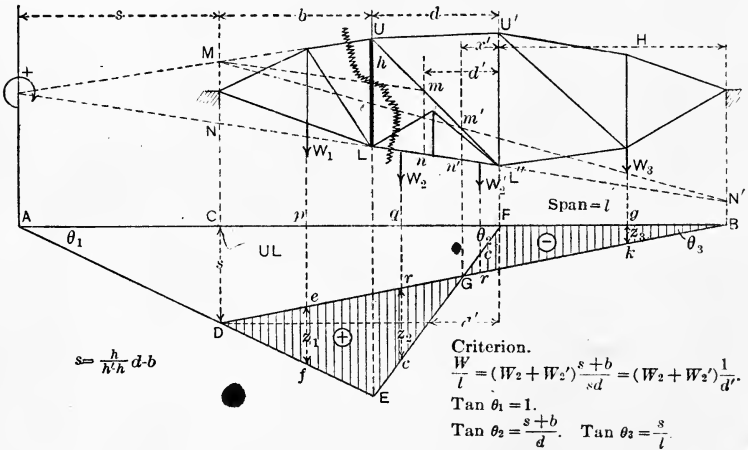

FIG. 10.

The auxiliary truss acts simply as a *trussed stringer*. The construction of the influence diagram follows the general rule using the horizontal projection of LL'' as the length

of the *cut stringer*. The graphical determinations of d' and x' are clearly shown in Fig. 10.

The criterion for wheel loads producing maximum moment is is

$$\frac{W}{l} = (W_2 + W_2') \frac{s+b}{sd} = (W_2 + W_2') \frac{1}{d'}. \quad \dots (49)$$

Upper Segment of Diagonal in Sub-hanger Truss.—The member UV in Fig. 11, is a part of the diagonal UL'' of

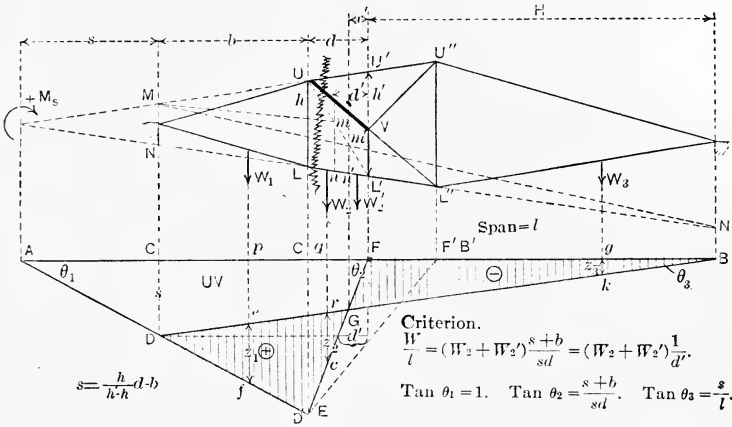

FIG. 11.

the main truss and also a chord member of the auxiliary truss UVU'' . The influence diagram for UL'' is $DEF'B'D$ and that for the chord UV is $D'FB'$. The combination of these two diagrams gives the influence diagram $DEFBD$. This diagram is constructed according to the general rule when the horizontal projection of UV is taken as the length of the *cut stringer*. The graphical determination of x' and d' requires no explanation as the constructions are evident in Fig. 11.

The criterion for wheel loads producing maximum moment is

$$\frac{W}{l} = \frac{W_2 + W_2'}{d'} \dots \dots \dots (50)$$

Lower Segment of Diagonal in Sub-hanger Truss.—As in the case of the upper segment in the sub-strut truss this member is a part of the diagonal of the main truss and has

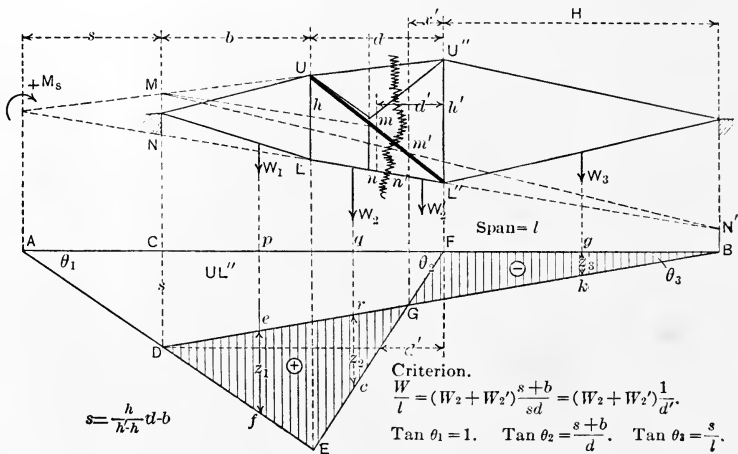

FIG. 12.

its stress only. Taking the horizontal projection of UL'' as the length of the *cut stringer* the influence diagram $DEFBD$, Fig. 12, is constructed according to the general rule. The distances d' and x' are found in the usual manner.

The criterion for wheel loads producing maximum moment is

$$\frac{W}{l} = \frac{W_2 + W_2'}{d'} \dots \dots \dots (51)$$

Vertical of Sub-hanger Truss.—In Fig. 13, the *cut stringer* for the vertical UL is the horizontal projection of LL' , since no part of the load on $L'L''$ is supported at L . The construction of the influence diagram follows the general rule. In determining x' and d' from the truss diagram, h' and the diagonal UL' form no part of the truss proper.

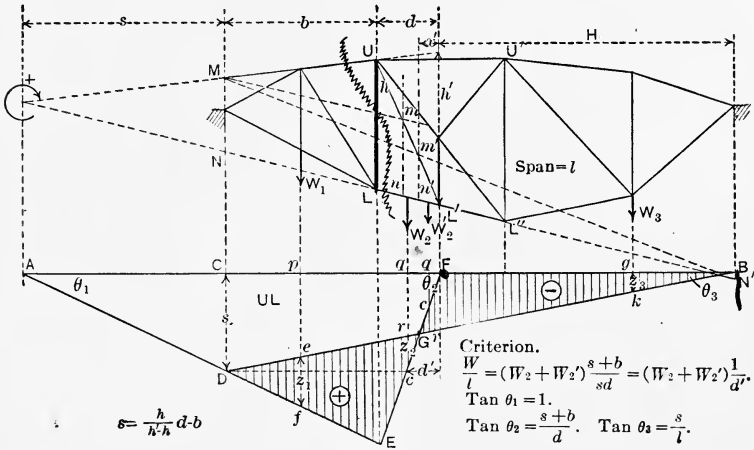

FIG. 13.

The criterion for wheel loads producing maximum moment is

$$\frac{W}{l} = \frac{W_2 + W_2'}{d'} \dots \dots \dots (52)$$

Bottom Chord of Sub-strut Truss.—The bottom chord L_4L_5 in Fig. 14 is a part of the chord of the main truss and also a part of the chord of the auxiliary truss L_3VL_5 . Considering only the chord L_3L_5 of the main truss the influence diagram is $DABD$. Now considering the chord L_4L_5 of the auxiliary truss L_3VL_5 and taking the center of

moments at V , the influence diagram, constructed according to the general rule, is $C'EB'F'C'$. The distance $C'D'$ is laid off equal to $(AK) \frac{(U_3 L_3)}{(VL_4)}$ in order that the moments may be equivalent to taking U_3 as a center of moments. The diagram is inverted and when combined with the

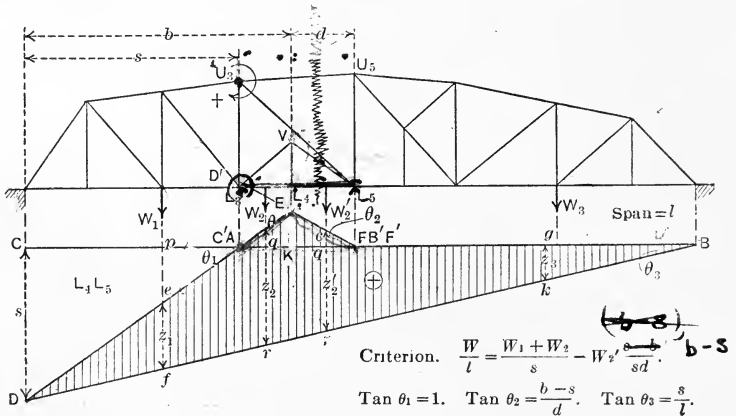

FIG. 14.

previous diagram the two form the influence diagram for VL_5 , as shown by the shaded area $DAEFBD$.

Referring to Fig. 14,

$$D'C' : EK :: AF : KF \quad \text{or} \quad EK = \frac{(D'C')(KF)}{AF};$$

but

$$D'C' = AK \frac{AF}{KF = d};$$

therefore

$$EK = \frac{(AK)(AF)}{KF} \cdot \frac{KF}{AF} = AK.$$

If the line DA is prolonged until it cuts the vertical through K the ordinate cut-off above K equals AK and hence it cuts the vertical at E , and EK in the small diagram equals EK of the large diagram. This shows, if the horizontal projection of VL_5 is taken as the length of the *cut stringer* and an influence diagram constructed according to the general rule, that this is the true influence diagram for VL_5 .

The criterion for wheel loads producing maximum moment is found as follows:

$$\frac{\delta M_s}{\delta x} = W_1(-\tan \theta_1 + \tan \theta_3) + W_2(-\tan \theta_1 + \tan \theta_3) + W_2'(\tan \theta_2 + \tan \theta_3) + W_3 \tan \theta_3 = 0; \quad (53)$$

then

$$W \tan \theta_3 = (W_1 + W_2) \tan \theta_1 - W_2' \tan \theta_2. \quad (54)$$

Substituting the values of the tangents and dividing through by s

$$\frac{W}{l} = (W_1 + W_2) \frac{1}{s} - W_2' \frac{b-s}{sd}. \quad (55)$$

If $b-s=d$, then

$$\frac{W}{l} = \frac{W_1 + W_2 - W_2'}{s}. \quad (56)$$

Top Chord of Sub-strut Truss.—In Fig. 15 the top chord UU' has no double duty to perform as it is simply a chord member of the main truss. The influence diagram is drawn according to the general rule using the horizontal projection of the chord UU' as the length of the *cut stringer*.

The criterion for wheel loads producing maximum moment is

$$\frac{W}{l} = \frac{W_1 + W_2}{s} \dots \dots \dots (57)$$

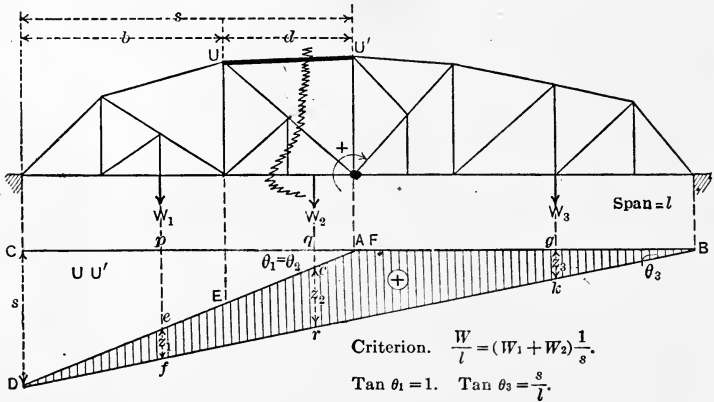

FIG. 15.

Top Chord of Sub-hanger Truss.—Referring to the explanations given for Fig. 14, the horizontal projection of *UV*, Fig. 16, is taken as the length of the *cut stringer* and the influence diagram constructed according to the general rule.

The criterion for wheel loads producing maximum moment is

$$\frac{W}{l} = \frac{W_1}{s} + \frac{W_2(s-b)}{sd} \dots \dots \dots (58)$$

If $s - b = 2d$, then

$$\frac{W}{l} = \frac{W_1 + 2W_2}{s} \dots \dots \dots (59)$$

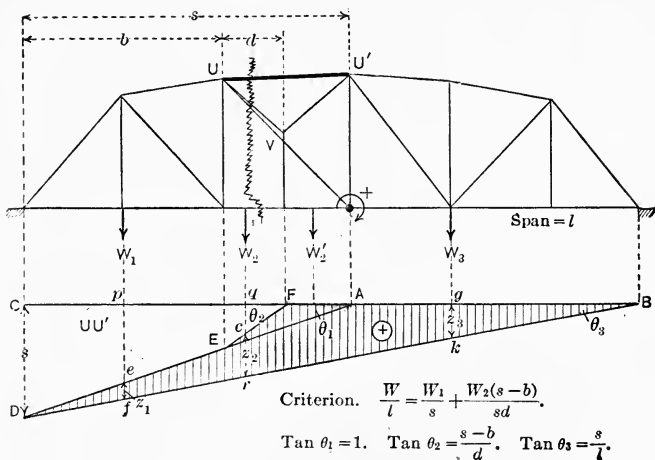

FIG. 16.

Bottom Chord of Sub-hanger Truss.—This case follows the general rule for simple trusses. The influence diagram is shown in Fig. 17.

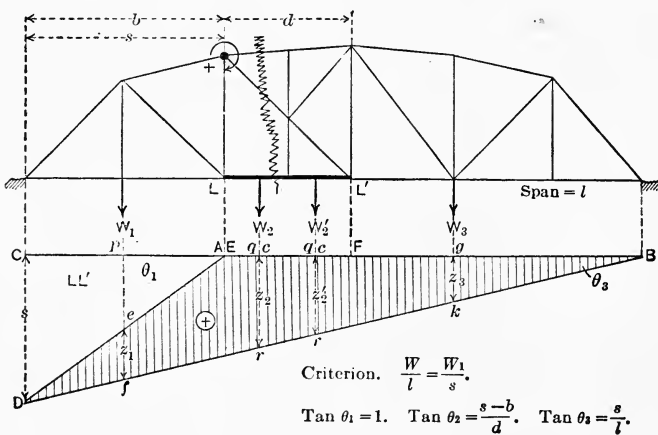

FIG. 17.

The criterion for wheel loads producing maximum moment is

$$\frac{W}{l} = \frac{W_1}{s} \cdot \cdot \cdot \cdot \cdot \cdot \cdot \cdot \cdot \quad (60)$$

The Length of the Cut Stringer for trusses with sub-struts or sub-hangers of the type considered above, can be readily determined by the following rules.

(a) *For diagonal members:* whenever the section cuts the segment which is a part of the main diagonal and also a part of the auxiliary truss, the length of the *cut stringer* is the horizontal projection of the segment cut.

(b) *For diagonal members:* whenever the section cuts the segment which is a part of the diagonal of the main truss and forms no part of the auxiliary truss, the length of the *cut stringer* is the horizontal projection of the diagonal of the main truss.

(c) *For chord members:* whenever the section cuts the chord which forms a part of the main truss chord and also a part of the auxiliary truss, the length of the *cut stringer* for this chord is the horizontal projection of the diagonal segment cut by the section. Otherwise the length of the *cut stringer* is the horizontal projection of the chord, of the main truss, which is cut.

(d) *For vertical members of the main truss:* whenever the section cuts any portion of the auxiliary truss the length of the *cut stringer* is the horizontal projection of the diagonal of the main truss. In case the section does not cut the auxiliary truss the length of the *cut stringer* is the horizontal projection of the segment of the diagonal adjacent to the vertical.

SPECIAL CASE

Diagonal of Simple Truss, Having Center of Moments between the Supports.—In Fig. 18 make a section cutting two chords and the diagonal UL' . The intersection of the two chord members is between the supports, a condition which has not obtained in any of the previous examples. The influence diagram for moments is constructed according

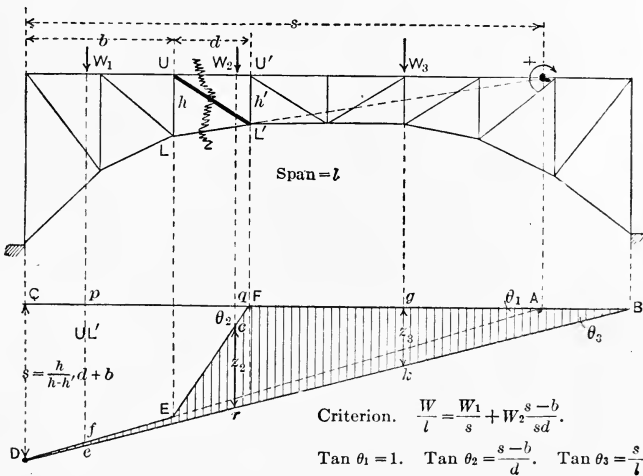

FIG. 18.

to the general rule and is shown by the shaded area in Fig. 18. This diagram shows that each and every load placed upon the span produces the same kind of stress in the diagonal UL' .

The criterion for the position of wheel loads which produce the maximum moment is found as follows:

$$\frac{\delta M_s}{\delta x} = W_1(-\tan \theta_1 + \tan \theta_3) + W_2(-\tan \theta_2 + \tan \theta_3) + W_3 \tan \theta_3 = 0, \dots \dots (61)$$

or

$$W \tan \theta_3 = W_1 \tan \theta_1 + W_2 \tan \theta_2. \quad \dots (62)$$

Substituting the values of the tangents

$$\frac{W}{l} = \frac{W_1}{s} + W_2 \frac{s-b}{sd}, \quad \dots \dots \dots (63)$$

where W is the total load on the span.

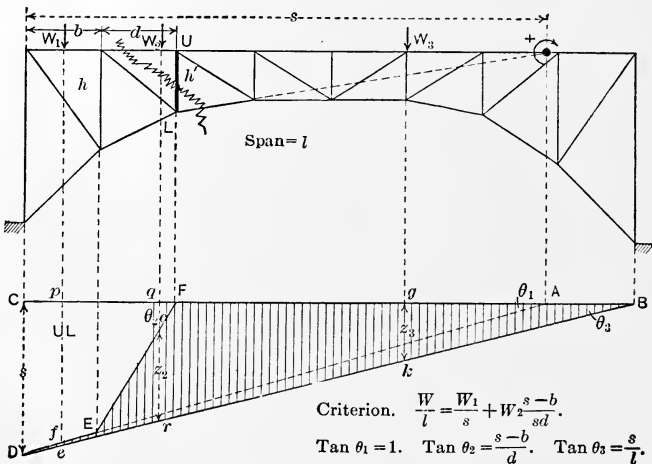

FIG. 19.

Vertical of Simple Truss Having Center of Moments between the Supports.—The vertical member UL , Fig. 19, has its center of moments between the supports. The moment influence diagram is constructed according to the general rule and is the shaded area in Fig. 19. This diagram

is similar to that in Fig. 18 and therefore the criterion locating wheel loads which produce the maximum moment is

$$\frac{W}{l} = \frac{W_1}{s} + W_2 \frac{s-b}{sd} \cdot \cdot \cdot \cdot \cdot \quad (64)$$

CHAPTER II

DOUBLE INTERSECTION TRUSSES

Double Intersection Trusses are made up of two or more simple trusses and the influence diagram for any member is found by first drawing the influence diagram for each simple truss and then connecting these diagrams so as to form one diagram. This is shown in the following examples.

Top Chord of Whipple Truss.—The Whipple truss shown in Fig. 20 is made up of two simple trusses as indicated by the full and dotted lines of the truss diagram.

The chord U_3U_4 is a part of the top chord of both trusses. Considering it as a top chord member of the truss shown by the full lines, the center of moments is at L_4 and the length of the *cut stringer* is L_4L_6 . The influence diagram $DAFBD$ is constructed according to the general rule. When the member U_3U_4 is considered as a part of the top chord of the dotted truss, the center of moments is at L_5 , the length of the *cut stringer* is L_5L_7 and the influence diagram is $DA'F'B'D'$. This diagram is constructed upon the line DB of the first diagram by making $D'C'$ equal s' . Now a load at L_2 does not affect the members of the dotted truss and hence the ordinate ef in the influence diagram for the truss shown by full lines is the correct moment for a unit load at L_2 . A load at L_3 by similar reasoning has for its true ordinate $e'f'$ in the influence diagram for the dotted truss. For a

load between L_2 and L_3 the influence line is a straight line connecting e and e' . In a like manner the other panel points are considered and the final influence diagram, shown by the shaded area, obtained. The loads at L_1 and L_{11} are assumed to be equally divided between the two trusses and hence the influence line passes midway between the two influence diagrams for these points.

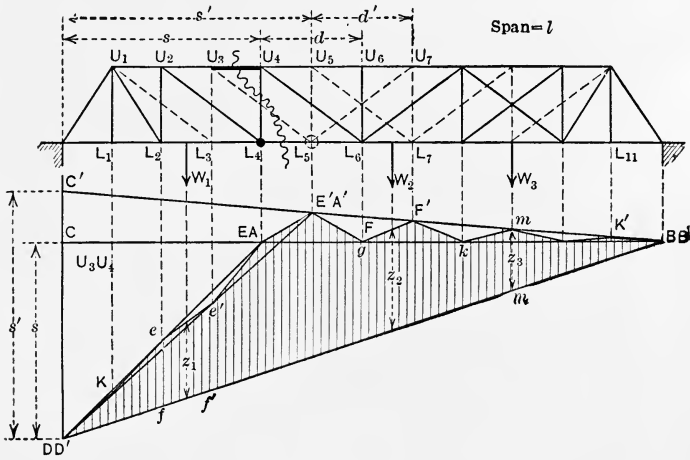

FIG. 20.

The position of wheel loads producing maximum moment is best found by trial. A criterion can be deduced but it is too complicated for practical use.

Vertical of Whipple Truss. — The vertical U_4L_4 is a member of the truss shown by the full lines, Fig. 21. The influence diagram for vertical shear in the panel cut is $DEFBD$. For loads at panel points L_2, L_4, L_6 , etc., the ordinates of this influence diagram are correct for unit loads. The loads at L_3, L_5, L_7 , etc., are supported entirely by the truss shown by dotted lines and hence do not contribute any shear in the panel being considered, of the

truss shown by the full lines. Therefore, the ordinates in the influence diagram directly below these points are zero. Connecting these points with the ends of the ordinates which are correct, as shown in Fig. 21, the influence diagram shown by the shaded area is obtained. The loads L_1 and L_{11} are assumed to be equally divided between the two trusses.

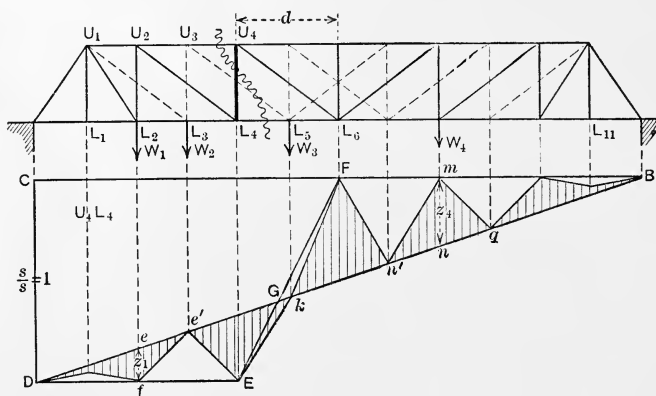

FIG. 21.

Diagonal of Whipple Truss.—The diagonal U_2L_4 , Fig. 22 is a member of the truss shown by full lines and its influence diagram is constructed in a manner similar to that explained for the vertical U_4L_4 . The influence diagram is shown by the shaded areas.

The position of wheel loads producing the maximum vertical shear is found by trial.

Top Chord of Sub-divided Double Triangular Truss.—The two principal trusses are shown in Fig. 23 by full and dotted lines. The top chord member U_6U_8 forms a part of each truss. The influence diagram for U_6U_8 as a member of the truss shown by full lines is $DABD$ and that for the truss shown by dotted lines is $D'A'B'$. Connecting these

two diagrams in the manner explained for the Whipple truss the influence diagram shown by the shaded area is obtained.

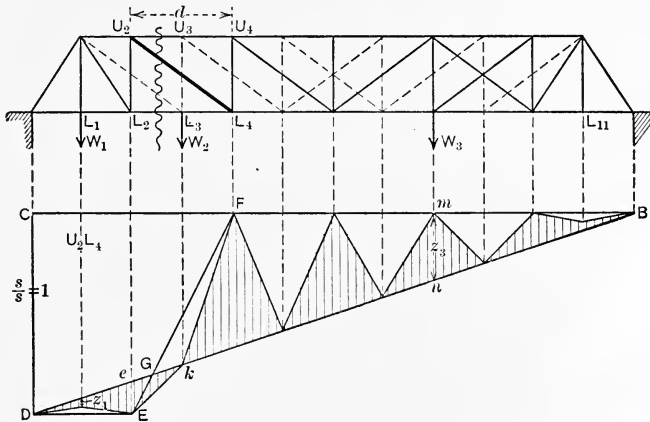

FIG. 22.

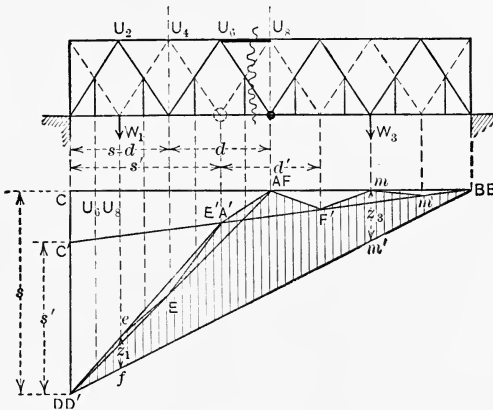

FIG. 23.

The position of wheel loads producing the maximum moment is found by trial.

Bottom Chord of Sub-divided Double Triangular Truss.—The bottom chord member L_4L_6 , Fig. 24 is a part of the

two simple trusses and also a part of the auxiliary frame $L_4M_3L_6$. Neglecting the auxiliary truss $L_4M_3L_6$, the influence diagram is drawn in the manner outlined for a top chord member. This diagram is $DED''B''Fn'$, etc., and for a load of unity anywhere between L_4 and L_6 the moment is equal to the ordinate immediately below the load between the lines $D''B''$ and DB , and the stress in L_4L_6 equals this moment divided by the depth of the truss. The stress in L_4L_6 as a part of the auxiliary truss $L_4M_3L_6$ can

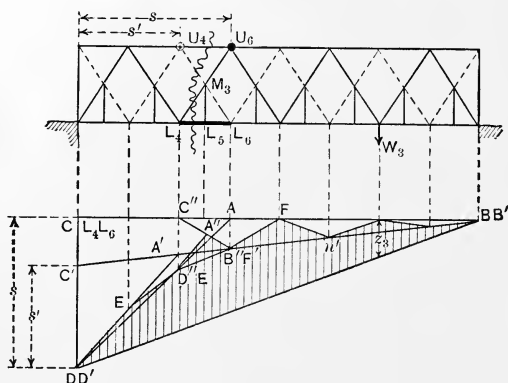

FIG. 24.

be found by drawing the influence diagram for L_4L_5 and dividing the ordinate directly below the load by the length L_5M_3 . If the scale of this diagram is properly taken the ordinates may be added directly to those of the large diagram.

Following the general rule for constructing influence diagrams, with $D''C''$, Fig. 24, equal to $s'' = L_4L_5$ multiplied by $L_4U_4 \div L_5M_3$, the diagram $D''A''B''$ is obtained. The ordinates are increased in the same ratio as the ratio of the lever arms of L_4L_6 . The shaded area is the influence diagram for L_4L_6 . This is simply the proper combination

a series of the letter K. Making a section cutting U_2U_3 , U_3M_2 , M_2L_3 and L_2L_3 , it at once appears that the upper and lower chord members in a panel have equal horizontal components since the centers of moments are in the same vertical line.

The construction of the influence diagram for moments

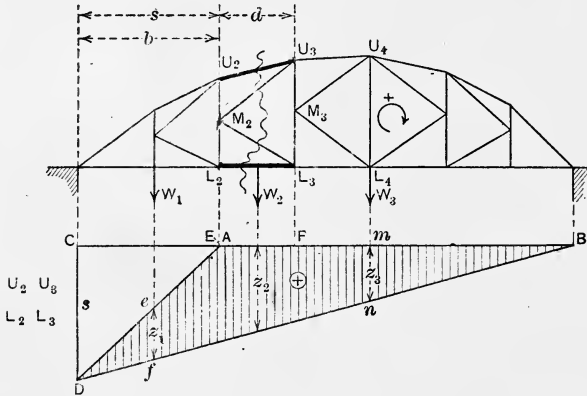

FIG. 26.

follows the general rule. The criterion for wheel loads which provide the maximum moment is

$$\frac{W}{l} = \frac{W_1}{s}, \quad \dots \dots \dots (65)$$

where W is the total load on the span and W_1 the total load between the left support of the truss and the center of moments of the chords considered.

Diagonal Web Members of the "K" Truss.—The usual method of sections cannot be employed as any section made through the truss cuts at least four members. From the arrangement of the diagonals it is clear that the pair in one panel must have horizontal components equal in

magnitude but opposite in character. The magnitude of this component is equal to the difference between the horizontal components of the stresses in the chords in the panel containing the diagonals being considered and the adjacent panel opposite the point of intersection of the diagonals. In Fig. 27 the horizontal components of the diagonals U_3M_2 and M_2L_3 is the difference between the horizontal components of the chords in this panel and the panel immediately upon the right.

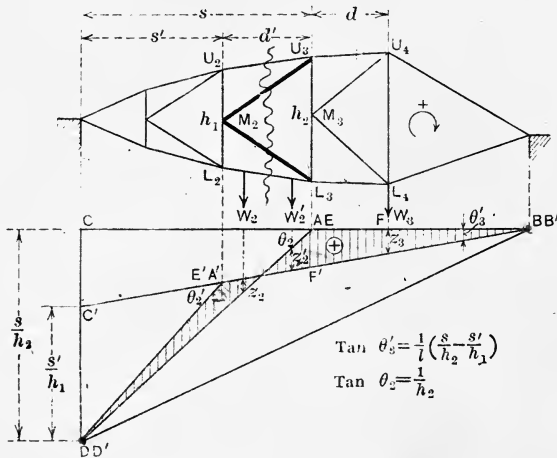

FIG. 27.

The influence diagram for the horizontal component of U_3U_4 and L_3L_4 can be constructed according to the general rule by laying off CD equal to $s \div h_2$. On DB as a base construct a similar diagram for the chords U_2U_3 and L_2L_3 , the difference between these diagrams as shown by the shaded areas in Fig. 27 being the influence diagram for the horizontal components of the diagonals U_3M_2 and M_2L_3 . The stress in any diagonal equals its horizontal component multiplied by the secant of the angle it makes with the horizontal.

The criterion for the position of wheel loads which produce maximum stresses is found as follows:

$$-W_2(-\tan \theta_3' + \tan \theta_2) + W_2'(\tan \theta_3' - \tan \theta_2) + W_3 \tan \theta_3' = 0, \quad (66)$$

or

$$W(\tan \theta_3') = (W_2 + W_2') \tan \theta_2. \quad \dots \quad (67)$$

Substituting the values of the tangents,

~~$$\frac{(W_2 + W_2') h_1}{S h_1 - S' h_2} = \frac{W}{l} = (W_2 + W_2') \frac{h_2}{s h_2 - s' h_2'} \quad \dots \quad (68)$$~~

In case the chords are parallel, then $h_1 = h_2$ and $s - s' = d'$ and the criterion becomes the same as developed for Fig. 4.

Upper Segment of Vertical in the "K" Truss.—In Fig. 28 a section cutting the upper segment of the vertical U_3L_3

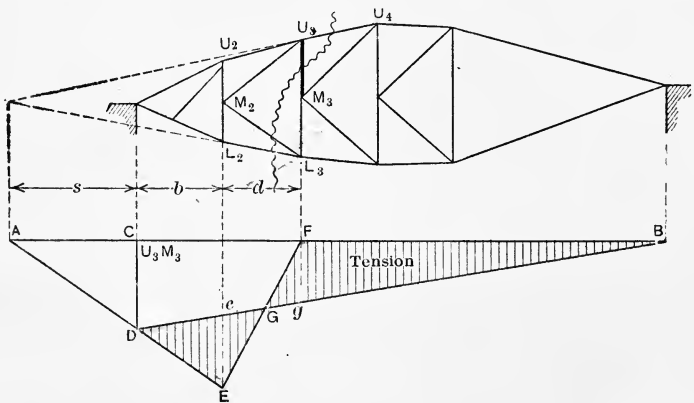

FIG. 28.

also cuts the members U_3U_4 , M_2L_3 , and L_2L_3 . Taking the center of moments at the intersection of the chord members U_3U_4 and L_2L_3 , the moment influence diagram

is constructed according to the general rule. In this case the stress in U_3M_3 is not equal to the ordinates of the diagram divided by the lever arm $s+b+d$, since a portion of each ordinate corresponds to the moment of the stress in the diagonal M_2L_3 . The simplest way to utilize the influence diagram is to first determine the stress in U_3M_3 for a unit load at L_3 . (This can be very quickly done graphically.) Then below F in the influence diagram lay

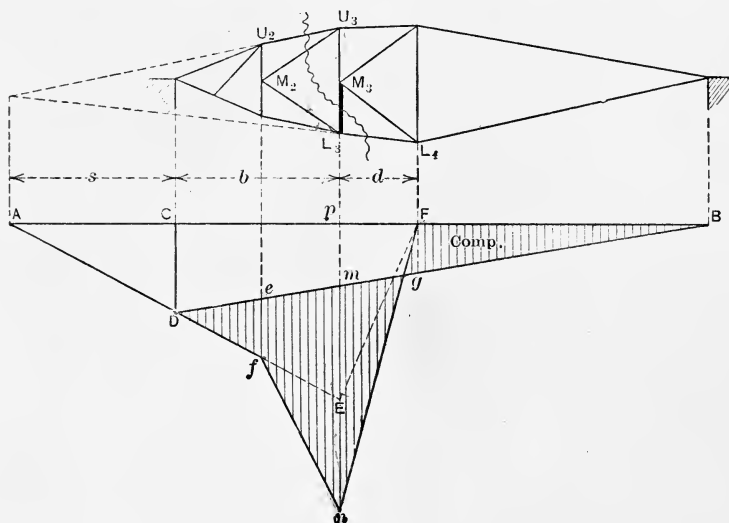

FIG. 29.

off to any convenient scale the distance Fg equal to this stress. Draw a straight line through B and g and extend it until the point D is located. Complete the diagram according to the general rule. The ordinates in this diagram correspond to the actual stresses in the piece U_3M_3 produced by a unit load moving across the span.

Lower Segment of Vertical in the "K" Truss.—As in the case of the upper segment it is impossible to make a section which does not cut at least four members of the truss. Practically the same method is employed as outlined for

the upper segment. Graphically determine the stress in M_3L_3 produced by a unit load at L_4 and lay off this stress below F as Fg . Locate D by drawing a straight line through B and g and then complete the influence diagram according to the general rule. This gives the diagram $DEFBD$. A unit load at L_3 produces a stress in M_3L_3 due to its position in the principal truss and also a local stress considering M_3L_3 as a piece which simply transfers a portion of the load at L_3 to the main truss. While the stress in M_3L_3 produced by a unit load at L_3 is readily computed yet it is usually more satisfactory to find this stress graphically by means of an ordinary stress diagram. After this stress is found, lay off mn equal to it and connect f and n and F and n . The shaded area shown is the stress influence diagram for the member M_3L_3 .

CHAPTER III

CONTINUOUS TRUSSES

The **Moment Influence Diagrams** for various forms of simple trusses have been explained in detail and found to follow a single general rule in their construction. After the distance of the center of moments from the left support of the span is determined the diagram is constructed without further calculations and the ordinates are the moments for unit loads, on the truss, directly above.

For trusses which are continuous, or partially continuous, the moment influence diagrams are founded upon the influence diagram for simple trusses. The diagram for simple trusses will be called the *base diagram* for convenience.

General Moment Formula.—Considering any span of a continuous girder, let

M_s = the moment about a center of moments distant s from the left end of the span.

M_L = the bending moment at the left end of the span.

M_R = the bending moment at the right end of the span.

S_L = the vertical shear at the left end of the span.

W = any concentrated vertical load in the span.

a = the distance of W from the left end of the span.

R_1 = the left reaction produced by W considering the span as a simple beam on two supports.

l = the length of the span.

m_s = the moment about a center of moments distant s from the left support of the truss, considering the truss as a simple girder on two supports.

s = the distance of the center of moments from the left end of the span. Positive when measured to the right.

Then

$$M_s = M_L + S_L s - W(s - a)^{s > a}, \quad \dots \dots (a)$$

but

$$S_L = \frac{M_R - M_L}{l} + R_1; \quad \dots \dots (b)$$

therefore

$$M_s = M_L + \frac{M_R - M_L}{l} s + R_1 s - W(s - a)^{s > a}. \quad \dots (c)$$

Now, $R_1 s - W(s - a)^{s > a} = m_s$,

hence

$$M_s = M_L \frac{l - s}{s} + M_R \frac{s}{l} + m_s. \quad \dots \dots (d)$$

This expression shows that the influence diagram for M_s may be considered as being composed of two separate diagrams combined algebraically. One of the diagrams is that for the common moment m_s or the *base diagram*. It will be shown in the problems which follow that the influence diagram for M_s can be easily constructed upon the base diagram and with a small amount of calculation.

Cantilever Truss.—Truss bridges which are called cantilever bridges are composed of anchor spans, cantilever spans and suspended spans. The simplest form of this combination is shown in Fig. 30.

Top Chord of Anchor Span.—Assume any chord as U_2U_3 , Fig. 30, with its center of moments at L_2 . For loads in this span the influence diagram is the *base diagram* representing the moments m_s in equation (d), since the moments M_L and M_R are zero.

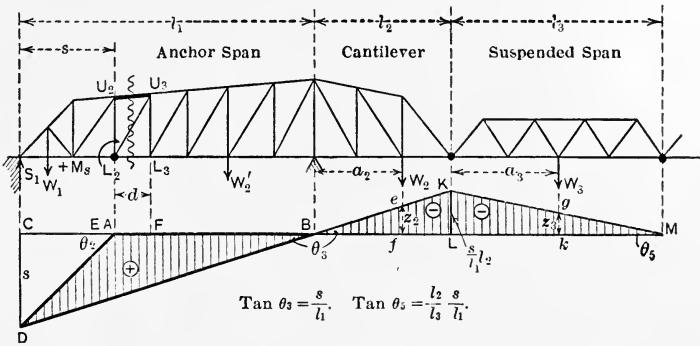

FIG. 30.

The criterion for wheel loads in this span which produce the maximum moment is

$$\frac{W_1}{s} = \frac{W_2'}{l-s} \dots \dots \dots (69)$$

For loads in the cantilever span $M_L=0$, $M_R = -W_2a_2$, and from equation (d),

$$M_s = -W_2a_2 \frac{s}{l_1} = -W_2a_2 \tan \theta_3 = W_2(-ef) \dots (70)$$

This shows that the lines DB and CB of the *base diagram* are extended until they cut the vertical through the right end of the cantilever. The influence diagram is shown by the shaded area BKL .

For loads in the suspended span,

$$M_L = 0, \quad M_R = -W_3 \frac{l_3 - a_3}{l_3} l_2, \quad m_s = 0,$$

and hence

$$M_s = -W_3 (l_3 - a_3) \frac{s}{l_1} \cdot \frac{l_2}{l_3}. \quad \dots \quad (71)$$

This is the equation for the straight line KM when $\tan \theta_5 = \frac{s}{l_1} \frac{l_2}{l_3} = \frac{KL}{l_3}$. The shaded area in Fig. 30 is the complete moment influence diagram for the chord $U_2 U_3$.

The criterion for wheel loads which produce the maximum *negative* moment is

$$\frac{W_2}{l_2} = \frac{W_3}{l_3}.$$

Top Chord of Cantilever Span.—The chord member, $U_1 U_2$, Fig. 31 will be considered. For loads in this span $M_L = -W_2 a_2$, $M_R = 0$ and hence, from equation (d),

$$M_s = -W_2 a_2 \frac{l_2 - s}{l_2} + m_s. \quad \dots \quad (72)$$

The *base diagram* is first constructed for the term m_s , as shown by the heavy lined triangle in Fig. 31. Prolong the line DA to K ; then from the triangle DKB ,

$$b'c' : KB :: a_2 : l_2,$$

Diagonal of Anchor Span.—As shown in Fig. 32, the diagonal U_3L_2 , has its center of moments at the intersection of the two cut chords U_2U_3 and L_2L_3 . For loads in this span the moment influence diagram is the base diagram as shown by heavy lined shaded figure in Fig. 32.

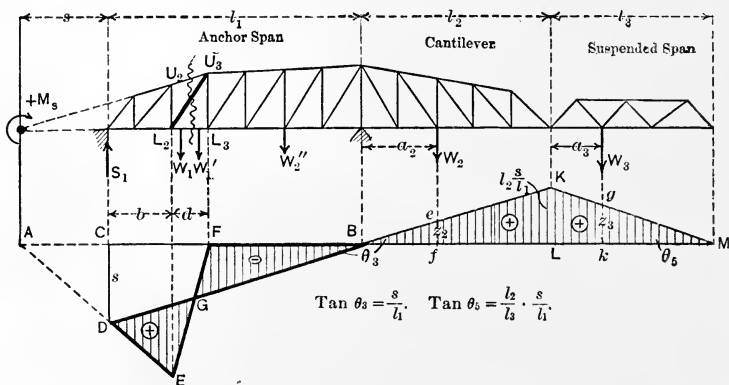

FIG. 32.

The criterion for wheel loads in this span which produce the maximum moment is

$$\frac{W}{l_1} = (W_1 + W_1') \frac{s + b}{sd} \dots \dots \dots (74)$$

For loads in the cantilever span, $M_L = 0$, $M_R = -W_2 a_2$, $m_s = 0$, and

$$M_s = -W_2 a_2 \left(\frac{-s}{l_1} \right) = W_2 a_2 \frac{s}{l_1} \dots \dots \dots (75)$$

Since $\frac{s}{l_1}$ is the tangent of the angle θ_3 the influence diagram for M_s is the shaded area $BKLM$.

For loads in the suspended span the influence diagram is the shaded area *KLM*.

The criterion for wheel loads which produce the maximum *positive* moment is

$$\frac{W_2}{l_2} = \frac{W_3}{l_3} \dots \dots \dots (76)$$

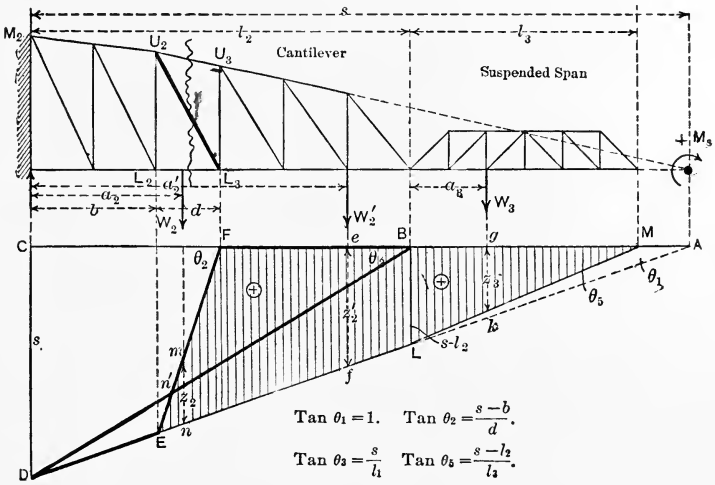

$$\begin{aligned} \tan \theta_1 &= 1. & \tan \theta_2 &= \frac{s-b}{d}. \\ \tan \theta_3 &= \frac{s}{l_1} & \tan \theta_4 &= \frac{s-l_2}{l_3}. \end{aligned}$$

FIG. 33.

Diagonal of Cantilever Span.—Referring to Fig. 33, for loads in the cantilever span $M_L = -W_2 a_2$, $M_R = 0$, and

$$M_s = -W_2 a_2 \frac{l_2 - s}{l_2} + m_s \dots \dots \dots (77)$$

The influence diagram for m_s is the base diagram shown by the heavy lines in Fig. 33. From the triangle DBL ,

$$n'n : BL :: a_2 : l_2,$$

and

$$n'n = \frac{a_2}{l_2}BL = \frac{a_2}{l_2}(s-l_2) = -a_2 \frac{l_2-s}{l_2}.$$

Therefore the triangle DBL is the influence diagram for $W_2 a_2 \frac{l_2-s}{l_2}$, where $W_2=1$. Combining this with the *base diagram*, the shaded figure $EFBL$ is obtained as the influence diagram for loads in this span.

For loads in the suspended span the influence diagram is the shaded area BLM .

The criterion for wheel loads producing the maximum moment is found as follows:

Without stating the intermediate equations

$$\frac{\delta M_s}{\delta x} = W_2 \left\{ -\frac{s-b}{d} + 1 \right\} + W_2' \left\{ 1 \right\} + W_3 \left\{ \frac{s-l_2}{l_3} \right\} = 0, \quad (78)$$

or

$$\frac{W_2}{d} = \frac{W_2'}{s-b-d} + \frac{W_3}{s-b-d} \frac{s-l_2}{l_3}. \quad \dots \quad (79)$$

If $s-l_2=l_3$,

$$\frac{W_2}{d} = \frac{W_2' + W_3}{s-b-d}. \quad \dots \quad (80)$$

CONTINUOUS AND PARTIALLY CONTINUOUS TRUSSES OF TWO EQUAL SPANS

Partially Continuous Truss.—In Fig. 34 is shown a common form of the revolving draw-bridge. The two end spans are equal and are separated by an unbraced

Therefore, from equation (d),

$$M_s = -W_1 l_1 \frac{k_1 - k_1^3}{4 + 6n} \frac{s}{l_1} + m_s. \quad \dots \quad (81)$$

Dividing through by s ,

$$\frac{M_s}{s} = -W_1 \frac{k_1 - k_1^3}{4 + 6n} + \frac{m_s}{s}. \quad \dots \quad (82)$$

The influence diagram for $\frac{m_s}{s}$ is represented by the *base diagram* drawn with $CD = 1$. This is shown in Fig. 34 by the heavy line triangle.

The value of $\frac{k_1 - k_1^3}{4 + 6n}$ is now computed for the positions of $W_1 = \text{unity}$, corresponding to the panel points of the truss. In the truss shown k_1 has the values 0, 1/5, 2/5, 3/5, 4/5, and 1. The corresponding values of $\frac{k_1 - k_1^3}{4 + 6n}$ are laid off as ordinates above the line DB directly below the panel points and the ends of the ordinates connected by straight lines forming the polygon $Dk'd'm'gB$. The influence diagram for $\frac{M_s}{s}$ is the shaded area shown in the figure. To obtain the value of M_s for any particular load the corresponding ordinate in the influence diagram is multiplied by s .

For any other center of moments as L_2 it is only necessary to draw one straight line as DA' to obtain the influence diagram.

In case the center of moments lies in a field covering about one-fifth the span l_1 , adjacent to the turntable, the line DA will cut the polygon $Dd'B$ and thereby indicate

the fields of loading in this span which produce moments of opposite character.

The position of wheel loads producing the maximum moment is best found by trial.

For loads in the third span

$$M_L = 0, \quad M_R = -W_3 l_3 \frac{2k_3 - 3k_3^2 + k_3^3}{4 + 6n}, \quad m_s = 0,$$

and

$$M_s = -W_3 l_3 \frac{2k_3 - 3k_3^2 + k_3^3}{4 + 6n} \frac{s}{l_1} \dots \dots \dots (83)$$

Remembering that $l_1 = l_3 = l$ and dividing through by s ,

$$\frac{M_s}{s} = -W_3 \frac{2k_3 - 3k_3^2 + k_3^3}{4 + 6n} \dots \dots \dots (84)$$

The influence diagram corresponding to this expression is shown by the shaded area BKM , Fig. 34.

The position of wheel loads producing the maximum moment is found by trial. This position when found will remain constant for all centers of moments in the first span.

VALUES OF $\frac{k-k^3}{4}$

Unit Load at	NUMBER OF PANELS IN SPAN.					
	4	5	6	7	8	9
L_1	.0586	.048	.0406	.0350	.0308	.0274
L_2	.0938	.084	.0740	.0656	.0586	.0527
L_3	.0820	.096	.0937	.0874	.0806	.0740
L_4		.072	.0925	.0962	.0938	.0891
L_5			.0637	.0875	.0952	.0960
L_6				.0568	.0820	.0925
L_7					.0513	.0767
L_8						.0466

The above table contains the values of $\frac{k-k^3}{4}$ for unit loads placed at the panel points of trusses having from four to nine panels. These values multiplied by $\frac{4}{4+6n}$ give the ordinates represented by $\frac{k-k^3}{4+6n}$. If the ordinates in any particular case are laid off in an inverse order the resulting polygon will represent the expression $\frac{2k-3k^2+k^3}{4+6n}$.

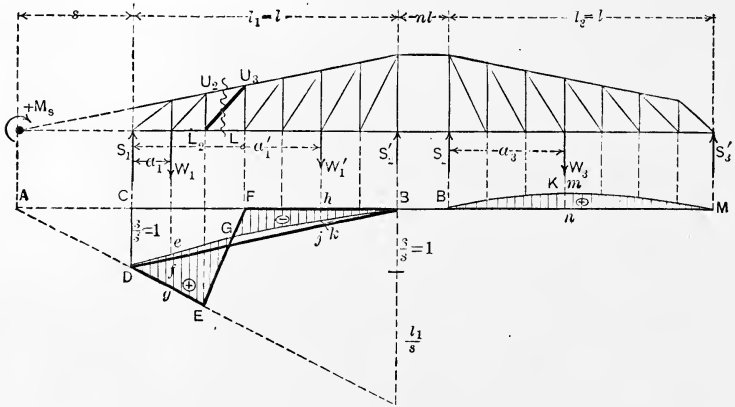

FIG. 35.

Diagonal of a Partially Continuous Truss.—The diagonal L_2U_3 in Fig. 35 has its center of moments at the intersection of U_2U_3 and L_2L_3 . Since the point of intersection lies upon the left of the left end of the span, s is negative.

For loads in this span,

$$M_L = 0, \quad M_R = -W_1 l_1 \frac{k-k^3}{4+6n},$$

and

$$\frac{I_s}{s} = W_1 \frac{k_1-k_1^3}{4+6n} + \frac{m_s}{s}. \quad \dots \dots \dots (85)$$

The influence diagram for $\frac{m_s}{s}$ is indicated by the heavy lines in Fig. 35. This is the *base diagram* with $CD = \text{unity}$. The ordinates represented by the expression $\frac{k_1 - k_1^3}{4 + 6n}$ are laid off above the line DB . The influence diagram for $\frac{M_s}{s}$ is the shaded area $DEGFB$. For any other diagonal the lines DE and EF , only are changed.

The position of wheel loads producing the maximum moment is found by trial. This is easily done as the influence areas are nearly triangular in form.

For loads in the third span,

$$M_L = 0, \quad M_R = -W_3 l_3 \frac{2k_3 - 3k_3^2 + k_3^3}{4 + 6n}, \quad m_s = 0,$$

and

$$\frac{M_s}{s} = W_3 \frac{2k_3 - 3k_3^2 + k_3^3}{4 + 6n}. \quad \dots \dots (86)$$

The influence diagram is indicated by the shaded area BKM .

As before, the position of wheel loads is found by trial.

Continuous Truss of Two Equal Spans.—If there is no short span over the turntable $n = 0$ and the only changes in the influence diagrams given above will be the ordinates to the polygonal figures. These will be increased in the ratio of $4 + 6n$ to 4.

CHAPTER IV

ARCHES

Arches with open webs and with solid webs will be considered. The three-hinged and the two-hinged arch can be handled with but little labor. The influence diagrams for fixed arches are complicated and are best constructed from computed ordinates.

Equation (d) is now modified by the moment of the horizontal thrust. If the lever arm of the horizontal thrust, H , is represented by y , then

$$M_s = M_L \frac{l-s}{s} + M_R \frac{s}{l} - Hy + m_s. \quad (e)$$

Diagonals in a Three-hinged Arch with Open Web.—The frame diagram of a three-hinged arch is shown in Fig. 36 and the influence diagrams for the diagonals U_2L_3 and U_3L_4 are outlined in Figs. 36a and 36b.

Since there can be no bending moments at the hinges over the supports, M_L and M_R in equation (e) are zero, and

$$\frac{M_s}{y} = -H + \frac{m_s}{y}. \quad (87)$$

The influence diagram for $\frac{m_s}{y}$ is the *base diagram* con-

structed with $CD = \frac{s}{y}$. This is shown by the area surrounded by heavy lines in Fig. 36a.

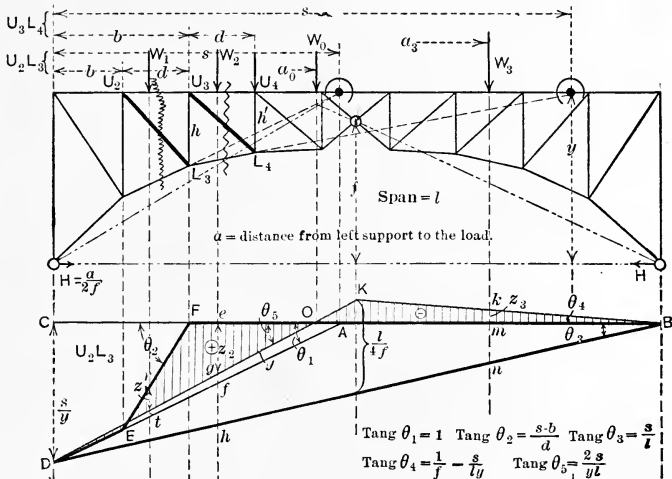

FIG. 36 a DIAGONAL U_2L_3

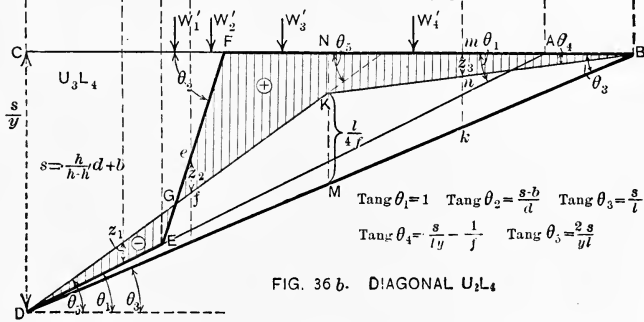

FIG. 36 b. DIAGONAL U_3L_4

FIG. 36.

The expression for H is

$$H = W \frac{a}{2f}$$

This indicates that H varies directly as the distances of the load from the supports and hence the influence diagram

for H will be a triangle between the support and the center hinge. Placing a unit load at the center hinge,

$$H = \frac{l}{4f}.$$

Lay off this distance above DB directly below the center hinge and thus locate the point K . Draw KD and KB ; then the shaded area is the influence diagram for $\frac{M_s}{y}$ corresponding to the diagonal U_2L_3 . Fig. 36*b* is a similar diagram for the diagonal U_3L_4 .

For chord members the same method is employed. The triangle DKB is constant for all influence diagrams.

The position of wheel loads producing the maximum moment is best found by trial as some of the criterions become too complex for easy application.

To illustrate the shape of one criterion, consider the influence diagram in Fig. 36*b* in deriving a criterion for the diagonal U_3L_4 .

$$\begin{aligned} \frac{\delta M_s}{\delta x} = & -W_1'(-\tan \theta_5 + \tan \theta_2) + W_2'(+\tan \theta_5 - \tan \theta_2) \\ & + W_3' \tan \theta_5 + W_4' \tan \theta_4 = 0, \quad . \quad (88) \end{aligned}$$

or

$$\begin{aligned} (W_1' + W_2' + W_3') \tan \theta_5 - (W_1' + W_2') \tan \theta_2 \\ + W_4' \tan \theta_4 = 0. \quad . \quad (89) \end{aligned}$$

Substituting the values of the tangents

$$(W_1' + W_2' + W_3') \frac{2s}{ly} = (W_1' + W_2') \frac{s-b}{d} - W_4' \left(\frac{s}{ly} - \frac{1}{f} \right). \quad (90)$$

Chord of Two-hinged Arch with Open Web.—As in the case of the three-hinged arch the moments M_L and M_R are zero, and

$$\frac{M_s}{y} = -H + \frac{m_s}{y} \dots \dots \dots (91)$$

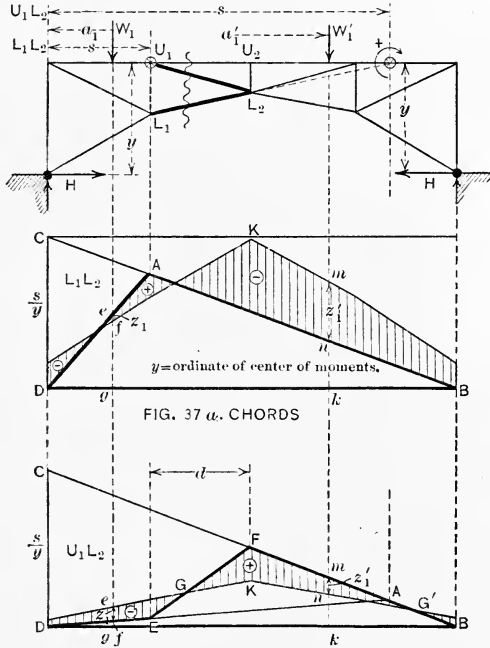

FIG. 37 b. WEB MEMBERS

FIG. 37.

The influence diagram for $\frac{m_s}{y}$ is the *base diagram* drawn with CD equal $\frac{s}{y}$. This is indicated by heavy lines in Fig. 37a. The values of H for a unit load at each panel point of the loaded chord are computed and laid off above DB and the upper ends connected by straight lines. The

The position of wheel loads producing the maximum moment is found by trial.

Moment Influence Diagram for Two-hinged Arch with Solid Web.—For the solid arch the influence diagram is quite simple as it is made up of the combination of the *base diagram* and the diagram for H , corresponding to unit loads, which is a smooth curve. The moment influence diagram is shown by the shaded area in Fig. 38a. For any other center of moments than the one indicated it is necessary to change only the lines CB and DA .

Vertical Shear for Two-hinged Arch with Solid Web.—The influence diagram for vertical shear is the same as explained for simple trusses on two supports by making the length of the cut stringer zero so that E and F of the *base diagram* lie in the same vertical line. This diagram is shown in Fig. 38b.

CHAPTER V

BEAMS OF CONSTANT CROSS-SECTION

The **Influence Diagrams** for beams are but little different from those which have been explained. In all cases the final diagram can be constructed upon the base diagram.

Restrained Beams.—Referring to Fig. 39, the moment at any section X is given by equation (d) or

$$M_s = M_R \frac{l-s}{l} + M_L \frac{s}{l} + m_s. \quad \dots \quad (d)$$

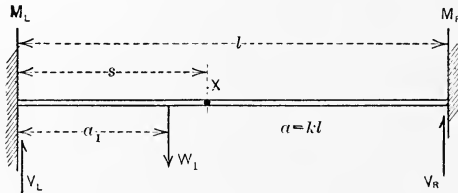

FIG. 39.

If the vertical shear at the section X is represented by S_s ,

$$S_s = V_L - \sum W = \frac{M_R - M_L}{l} + R_1 - \sum W. \quad \dots \quad (92)$$

But $R_1 - \sum W = S =$ the vertical shear for a simple beam resting upon two supports; therefore

$$S_s = \frac{M_R - M_L}{l} + S. \quad \dots \quad (f)$$

Simple Beam on Two Supports.—For a simple beam resting upon two supports M_L and M_R are zero, hence

$$M_s = m_s \quad \text{and} \quad S_s = S.$$

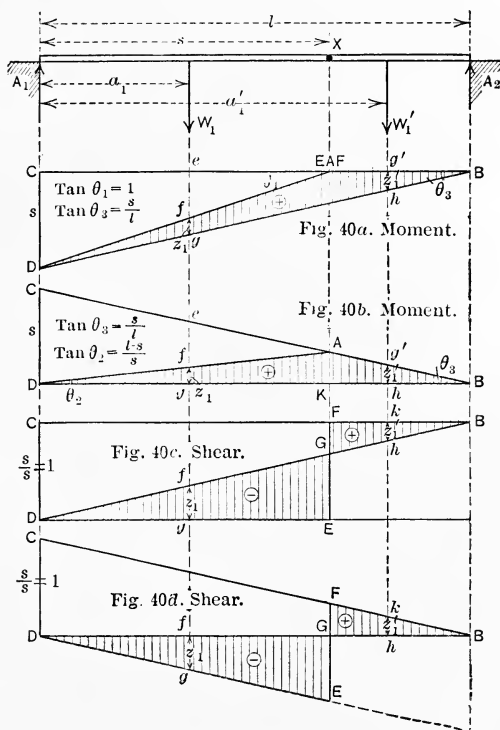

FIG. 40.

The influence diagrams for m_s and S are *base diagrams* constructed according to the general rule. Figs. 40a and 40b show moment influence diagrams. In one diagram CB is drawn horizontal according to rule, while in the other DB is horizontal. Evidently the ordinates are the same in both figures.

Beam Fixed at Both Ends.—In this case,

$$M_L = -Wl(k - 2k^2 + k^3), \quad M_R = -Wl(k^2 - k^3),$$

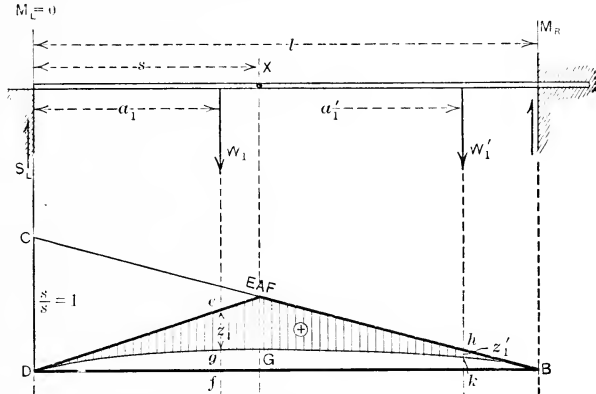

FIG. 41 a. MOMENTS

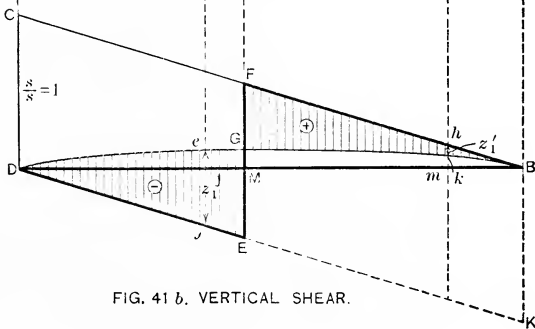

FIG. 41 b. VERTICAL SHEAR.

FIG. 41.

and

$$M_s = -Wl(k - 2k^2 + k^3) \frac{l-s}{l} - Wl(k^2 - k^3) \frac{s}{l} + m_s,$$

or

$$\frac{M_s}{s} = -W(k - 2k^2 + k^3) \frac{l-s}{l} - W(k^2 - k^3) + \frac{m_s}{s}. \quad (96)$$

The *base diagram* indicated by the heavy lines in Fig. 42a, is the influence diagram for $\frac{m_s}{s}$. The ordinates to

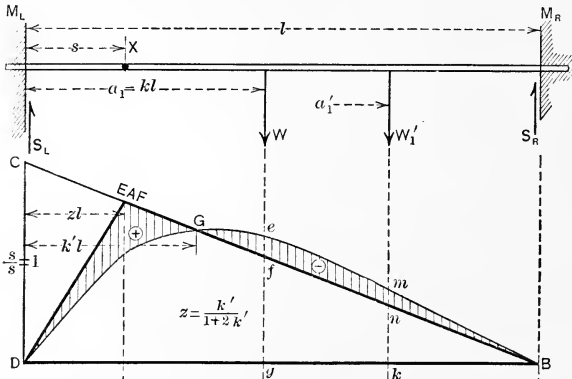

FIG. 42 a. MOMENTS

FIG. 42 b. VERTICAL SHEAR

FIG. 42.

the curve DGB are obtained by giving k corresponding values in the expression

$$-(k - 2k^2 + k^3) \frac{l-s}{l} - (k^2 - k^3).$$

Then the shaded area is the influence diagram for $\frac{M_s}{s}$.

For vertical shear

$$S_s = W(k - 3k^2 + 2k^3) + S. \quad \dots \quad (97)$$

The shaded area in Fig. 42b is the influence diagram for S_s .

VALUES OF $k^2 - k^3$ AND $k - 2k^2 + k^3$

k	$k^2 - k^3$		k	$k^2 - k^3$	
0	0	1.00			
.05	.002375	.95	.50	.125000	.50
.10	.009000	.90	.55	.136125	.45
.15	.019125	.85	.60	.144000	.40
.20	.032000	.80	.65	.147875	.35
.25	.046875	.75	.70	.147000	.30
.30	.063000	.70	.75	.140625	.25
.35	.079625	.65	.80	.128000	.20
.40	.096000	.60	.85	.108375	.15
.45	.111375	.55	.90	.081000	.10
.50	.125000	.50	.95	.045125	.05
			1.00	0	0
	$k - 2k^2 + k^3$	k		$k - 2k^2 + k^3$	k

$k - 3k^2 + 2k^3 = (k - 2k^2 + k^3) - (k^2 - k^3)$



THE
LIBRARY OF THE
UNIVERSITY OF TORONTO





THIS BOOK IS DUE ON THE LAST DATE
STAMPED BELOW

AN INITIAL FINE OF 25 CENTS
WILL BE ASSESSED FOR FAILURE TO RETURN
THIS BOOK ON THE DATE DUE. THE PENALTY
WILL INCREASE TO 50 CENTS ON THE FOURTH
DAY AND TO \$1.00 ON THE SEVENTH DAY
OVERDUE.

DEC 6 1941

DEC 20 1941

AUG 4 1942

MAR 19 1943

OCT 4 1945

OCT 11 1945

SEP 10 1947

LIBRARY USE

JUL 10 1956

2
1-100m-7:40 (6936s)

129

THE UNIVERSITY OF CALIFORNIA LIBRARY

